

## CONSTRUCTION/ASSEMBLY NOTES:

- PANEL SURFACES:** SOLID FACE IS 16 GA. COLD ROLLED STEEL WITH A-60 GALVANNEAL COATING. PERFORATED FACE IS 22 GA. WITH  $\frac{3}{32}$ " HOLES ON  $\frac{3}{16}$ " STAGGERED CENTERS.
- PANEL FILL:** NON-COMBUSTIBLE, SOUND ABSORBING FIBERGLASS
- FINISH:** STD. FINISH IS "PAINT READY" GALVANNEAL. THERMOSETTING TGIC POLYESTER POWDER COATING IS AVAILABLE. COLOR TO BE SELECTED BY ARCHITECT/CUSTOMER FROM STANDARD COLOR CHART SUPPLIED BY NOISE BARRIERS, LLC. COLOR TO BE: \_\_\_\_\_
- PANELS SHALL BE LOWERED CONSECUTIVELY BETWEEN VERTICAL WIDE FLANGED BEAMS. BARRIER WALL SHALL BE DESIGNED TO WITHSTAND WINDLOAD IN ACCORDANCE WITH THE SPECIFIED LOCAL CODE REQUIREMENTS OF THE PROJECT. REFER TO INSTALLATION DETAILS 'OPTION 1' & 'OPTION 2' FOR ALTERNATES.
- THE BARRIER PANEL ARE DESIGNED TO WITHSTAND WIND LOADS OF 40 POUNDS PER SQUARE FOOT, BOTH NEGATIVE AND POSITIVE.
- STRUCTURAL STEEL COLUMNS ARE PRIME PAINTED & FINISH PAINTED IN COLOR TO MATCH PANELS. PAINT TO BE SHOP APPLIED AND AIR DRIED.

## BARRIER PANEL ACOUSTIC PERFORMANCE

### SOUND TRANSMISSION LOSS, dB

OCTAVE BAND CENTER FREQUENCIES (Hz)	125	250	500	1K	2K	4K	STC
QUIETLINE H/P-42 V-STACK PANEL	23	31	40	49	56	62	42

\*All data in accordance with ASTM E90-99 and E413-87

### SOUND ABSORPTION COEFFICIENTS

OCTAVE BAND CENTER FREQUENCIES (Hz)	125	250	500	1K	2K	4K	NRC
QUIETLINE H/P-42 V-STACK PANEL	0.68	1.06	1.12	1.08	1.03	0.88	0.95 (1.05)

\*All data in accordance with ASTM C423-90a and E795-00

BARRIER WALL  
ISOMETRIC VIEW

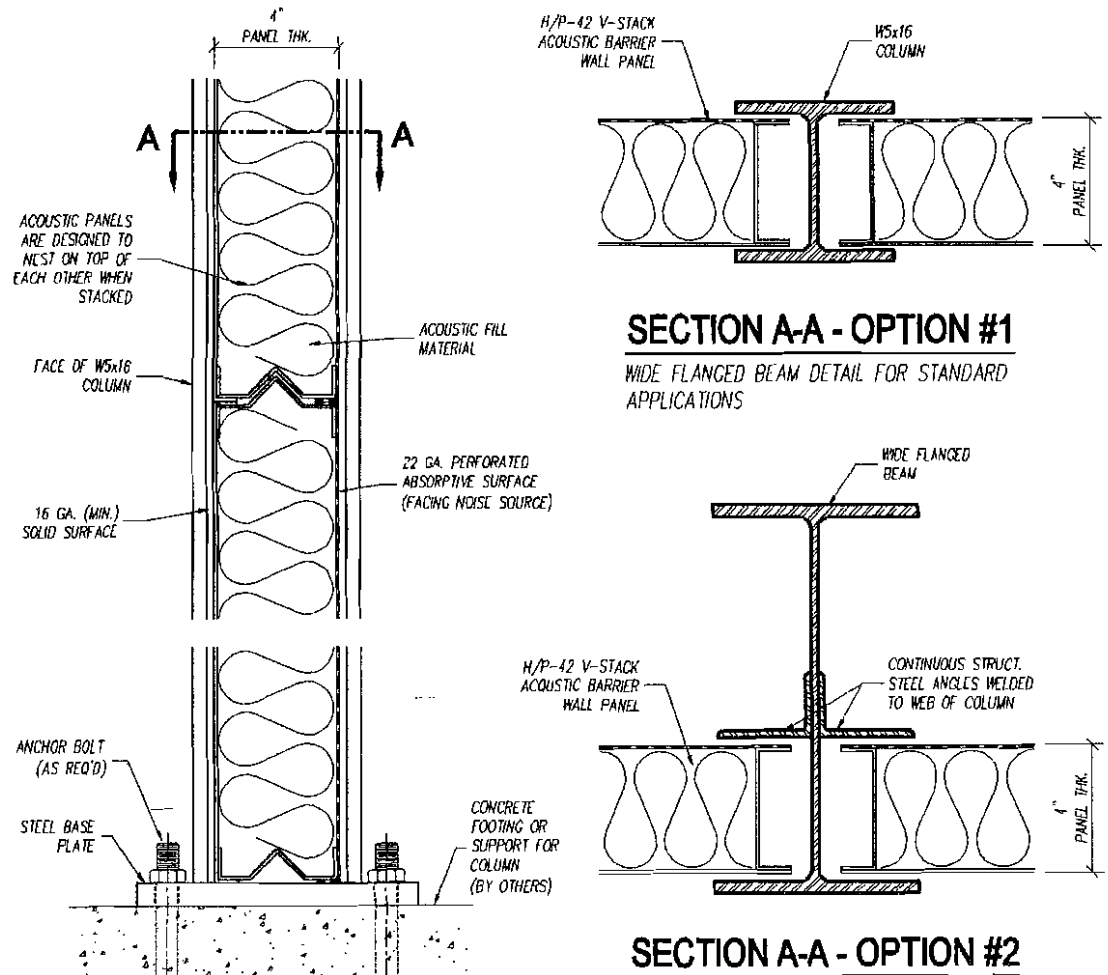
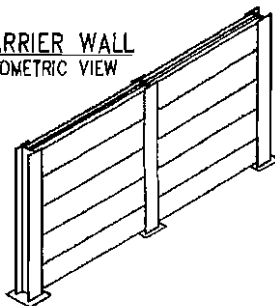

WALL SECTION DETAIL

REVISIONS	DESCRIPTION	DATE	BY	DESCRIPTION
				PROJECT
				DRAWN BY
				SCALE
				DRAWING NO.
				V-STACK-1
				SHEET



**Noise Barriers, LLC**

1207 Remington Rd., Suite E  
Schaumburg, IL 60173  
Phone: (847) 843-0500  
Fax: (847) 843-0501

www.noisebarriers.com

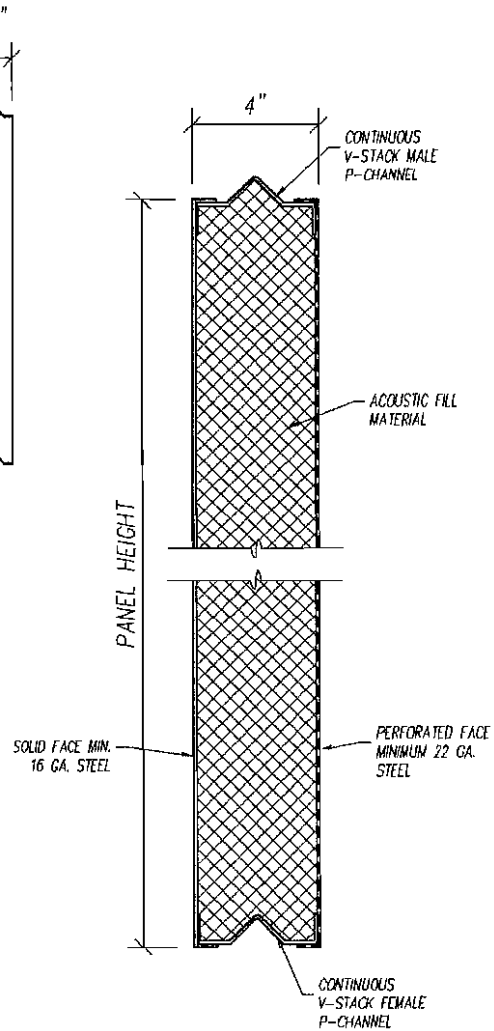
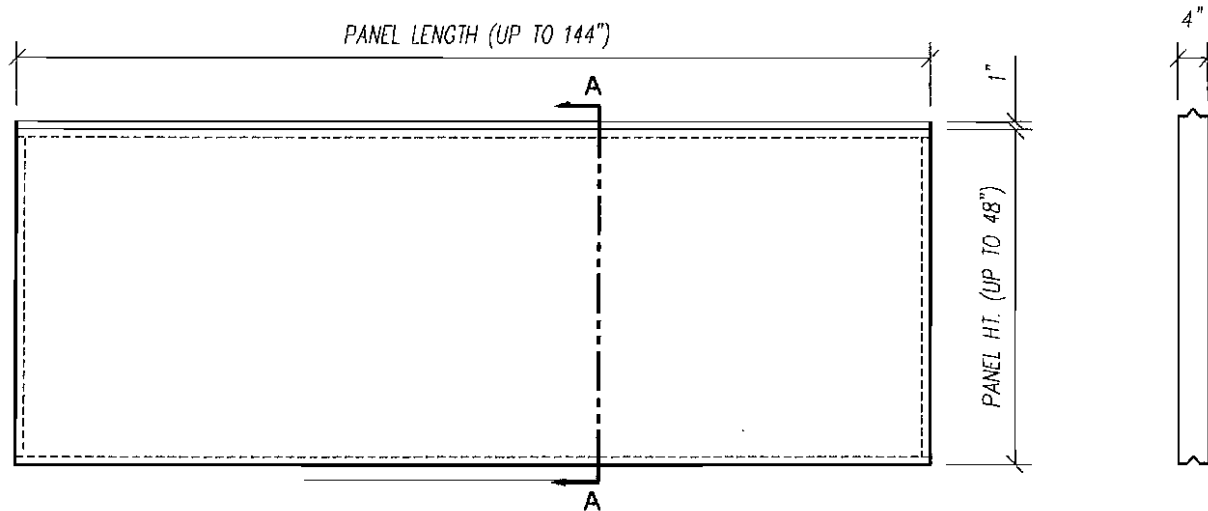

**V-STACK ACOUSTIC BARRIER WALL PANEL**  
**FRONT & SIDE ELEVATIONS**

PANEL No.	QTY.	PANEL LENGTH	PANEL HEIGHT

**SECTION A-A**

**'V-STACK' BARRIER PANEL**

REVISIONS	DESCRIPTION	DATE	BY	DESCRIPTION	<b>Noise Barriers, LLC</b> 1207 Remington Rd., Suite E Schaumburg, IL 60173 Phone: (847) 843-0500 Fax: (847) 843-0501 <a href="http://www.noisebarriers.com">www.noisebarriers.com</a>	
				QUIETLINE H/P V-STACK BARRIER PANEL		
				PROJECT		
				DRAWN BY	SCALE	PROJECT NO.
						V-STACK-2
				DATE	SHEET	